

**NORME  
INTERNATIONALE  
INTERNATIONAL  
STANDARD**

**CEI  
IEC**

**61724**

Première édition  
First edition  
1998-04

---

---

**Surveillance des qualités de fonctionnement  
des systèmes photovoltaïques –  
Recommandations pour la mesure,  
le transfert et l'analyse des données**

**Photovoltaic system performance monitoring –  
Guidelines for measurement,  
data exchange and analysis**

LICENSED TO MECON Limited, - RANCHI/BANGALORE  
FOR INTERNAL USE AT THIS LOCATION ONLY, SUPPLIED BY BOOK SUPPLY BUREAU.



Numéro de référence  
Reference number  
CEI/IEC 61724:1998

NORME  
INTERNATIONALE  
INTERNATIONAL  
STANDARD

CEI  
IEC

61724

Première édition  
First edition  
1998-04

---

---

**Surveillance des qualités de fonctionnement  
des systèmes photovoltaïques –  
Recommandations pour la mesure,  
le transfert et l'analyse des données**

**Photovoltaic system performance monitoring –  
Guidelines for measurement,  
data exchange and analysis**

LICENSED TO MECON Limited, - RANCHI/BANGALORE  
FOR INTERNAL USE AT THIS LOCATION ONLY, SUPPLIED BY BOOK SUPPLY BUREAU.

© IEC 1998 Droits de reproduction réservés — Copyright - all rights reserved

Aucune partie de cette publication ne peut être reproduite ni utilisée sous quelque forme que ce soit et par aucun procédé, électronique ou mécanique, y compris la photocopie et les microfilms, sans l'accord écrit de l'éditeur.

No part of this publication may be reproduced or utilized in any form or by any means, electronic or mechanical, including photocopying and microfilm, without permission in writing from the publisher.

International Electrotechnical Commission 3, rue de Varembé Geneva, Switzerland  
Telefax: +41 22 919 0300 e-mail: [inmail@iec.ch](mailto:inmail@iec.ch) IEC web site <http://www.iec.ch>



Commission Electrotechnique Internationale  
International Electrotechnical Commission  
Международная Электротехническая Комиссия

CODE PRIX R  
PRICE CODE

*Pour prix, voir catalogue en vigueur  
For price, see current catalogue*

## CONTENTS

	Page
FOREWORD .....	5
INTRODUCTION .....	7
Clause	
1 Scope .....	9
2 Normative references .....	9
3 Measured parameters .....	9
4 Monitoring method .....	13
4.1 Measurement of irradiance .....	13
4.2 Measurement of ambient air temperature .....	13
4.3 Measurement of wind speed .....	13
4.4 Measurement of module temperature .....	15
4.5 Measurement of voltage and current .....	15
4.6 Measurement of electrical power .....	15
4.7 Data acquisition system .....	15
4.8 Sampling interval .....	15
4.9 Data processing operation .....	17
4.10 Recording interval, $\tau_r$ (expressed in hours) .....	17
4.11 Monitoring period .....	17
5 Documentation .....	17
6 Data format .....	17
6.1 Separate header with multiple data records .....	19
6.2 Single record format .....	21
7 Check of data quality .....	21
8 Derived parameters .....	21
8.1 Global irradiation .....	23
8.2 Electrical energy quantities .....	27
8.3 BOS component performance .....	27
8.4 System performance indices .....	29
 Annex A (informative) A suggested method of checking the data acquisition system .....	 35
 Figure 1 – Parameters to be measured in real time .....	 13
 Table 1 – Parameters to be measured in real time .....	 11
Table 2 – Derived parameters .....	25

 LICENSED TO MECON Limited, - RANCHI/BANGALORE  
 FOR INTERNAL USE AT THIS LOCATION ONLY, SUPPLIED BY BOOK SUPPLY BUREAU.

## INTERNATIONAL ELECTROTECHNICAL COMMISSION

**PHOTOVOLTAIC SYSTEM PERFORMANCE MONITORING –  
GUIDELINES FOR MEASUREMENT,  
DATA EXCHANGE AND ANALYSIS**

## FOREWORD

- 1) The IEC (International Electrotechnical Commission) is a worldwide organization for standardization comprising all national electrotechnical committees (IEC National Committees). The object of the IEC is to promote international co-operation on all questions concerning standardization in the electrical and electronic fields. To this end and in addition to other activities, the IEC publishes International Standards. Their preparation is entrusted to technical committees; any IEC National Committee interested in the subject dealt with may participate in this preparatory work. International, governmental and non-governmental organizations liaising with the IEC also participate in this preparation. The IEC collaborates closely with the International Organization for Standardization (ISO) in accordance with conditions determined by agreement between the two organizations.
- 2) The formal decisions or agreements of the IEC on technical matters express, as nearly as possible, an international consensus of opinion on the relevant subjects since each technical committee has representation from all interested National Committees.
- 3) The documents produced have the form of recommendations for international use and are published in the form of standards, technical reports or guides and they are accepted by the National Committees in that sense.
- 4) In order to promote international unification, IEC National Committees undertake to apply IEC International Standards transparently to the maximum extent possible in their national and regional standards. Any divergence between the IEC Standard and the corresponding national or regional standard shall be clearly indicated in the latter.
- 5) The IEC provides no marking procedure to indicate its approval and cannot be rendered responsible for any equipment declared to be in conformity with one of its standards.
- 6) Attention is drawn to the possibility that some of the elements of this International Standard may be the subject of patent rights. The IEC shall not be held responsible for identifying any or all such patent rights.

International Standard IEC 61724 has been prepared by IEC technical committee 82: Solar photovoltaic energy systems.

This bilingual version (1998-04) replaces the English version.

The text of this standard is based on the following documents:

FDIS	Report on voting
82/189/FDIS	82/201/RVD

Full information on the voting for approval can be found in the report on voting indicated in the above table.

Annex A is for information only.

## INTRODUCTION

This standard describes general guidelines for the monitoring and analysis of the electrical performance of photovoltaic (PV) systems. It does not describe the performance of discrete components, but concentrates on evaluating the performance of an array as part of a PV system.

The intent of the data analysis is to provide a performance summary suitable for comparing PV installations of different sizes, operating in different climates, and providing energy for different uses, in such a way that the relative merits of different designs or operating procedures become evident. Simpler methods might be more cost effective for small, solar home or domestic stand-alone systems.

Guidelines are also included which describe a file format to be used for the exchange of monitoring data between organizations.

The use of a microprocessor-based data acquisition system for monitoring is required.

# PHOTOVOLTAIC SYSTEM PERFORMANCE MONITORING – GUIDELINES FOR MEASUREMENT, DATA EXCHANGE AND ANALYSIS

## 1 Scope

This International Standard recommends procedures for the monitoring of energy-related PV system characteristics such as in-plane irradiance, array output, storage input and output and power conditioner input and output; and for the exchange and analysis of monitored data. The purpose of these procedures is to assess the overall performance of PV systems configured as stand-alone or utility grid-connected, or as hybridised with non-PV power sources such as engine generators and wind turbines.

This standard may not be applicable to small stand-alone systems due to the relatively high cost of the measurement equipment.

## 2 Normative references

The following normative documents contain provisions which, through reference in this text, constitute provisions of this International Standard. At the time of publication, the editions indicated were valid. All normative documents are subject to revision, and parties to agreements based on this International Standard are encouraged to investigate the possibility of applying the most recent editions of the normative documents indicated below. Members of IEC and ISO maintain registers of currently valid International Standards.

IEC 60904-2:1989, *Photovoltaic devices – Part 2: Requirements for reference solar cells*  
Amendment 1 (1998)

IEC 60904-6:1994, *Photovoltaic devices – Part 6: Requirements for reference solar modules*  
Amendment 1 (1998)

IEC 61194:1992, *Characteristic parameters of stand-alone photovoltaic (PV) systems*

IEC 61829:1995, *Crystalline silicon photovoltaic (PV) array – On-site measurement of I-V characteristics*

## 3 Measured parameters

Parameters to be measured are shown in table 1 and figure 1. Other parameters can be calculated from the measured data in real time by the data acquisition system's software. Note that all blocks in figure 1 can represent multiple components. The measured parameters and array characteristics are defined in IEC 61194.

The parasitic power drawn by all ancillary systems shall be considered a power loss of the PV plant and shall not be considered a load. All monitoring systems not essential for the operation of the PV plant shall be considered part of the load. The monitoring equipment may present a major part of the overall power consumption, and the end user should be made aware that supplemental power may be required to satisfy the total load requirement.

**Table 1 – Parameters to be measured in real time**

Parameter	Symbol	Unit
Meteorology		
Total irradiance, in the plane of the array <sup>1)</sup>	$G_I$	$W \cdot m^{-2}$
Ambient air temperature in a radiation shield	$T_{am}$	$^{\circ}C$
Wind speed <sup>2)</sup>	$S_W$	$m \cdot s^{-1}$
Photovoltaic array		
Output voltage	$V_A$	V
Output current	$I_A$	A
Output power	$P_A$	kW
Module temperature	$T_m$	$^{\circ}C$
Tracker tilt angle <sup>5)</sup>	$\phi_T$	degrees
Tracker azimuth angle <sup>5)</sup>	$\phi_A$	degrees
Energy storage <sup>3)</sup>		
Operating voltage	$V_S$	V
Current to storage <sup>4)</sup>	$I_{TS}$	A
Current from storage <sup>4)</sup>	$I_{FS}$	A
Power to storage <sup>4)</sup>	$P_{TS}$	kW
Power from storage <sup>4)</sup>	$P_{FS}$	kW
Load <sup>3)</sup>		
Load voltage	$V_L$	V
Load current	$I_L$	A
Load power <sup>6)</sup>	$P_L$	kW
Utility grid <sup>3)</sup>		
Utility voltage	$V_U$	V
Current to utility grid <sup>4)</sup>	$I_{TU}$	A
Current from utility grid <sup>4)</sup>	$I_{FU}$	A
Power to utility grid <sup>4), 6)</sup>	$P_{TU}$	kW
Power from utility grid <sup>4), 6)</sup>	$P_{FU}$	kW
Back-up sources <sup>3)</sup>		
Output voltage	$V_{BU}$	V
Output current	$I_{BU}$	A
Output power	$P_{BU}$	kW
<p>1) Total irradiance, also known as the plane-of-array irradiance, defined as the radiant power, direct plus diffuse, incident upon unit area of an inclined surface.</p> <p>2) Parameters such as wind speed are optional, but may be required by special contract or if the PV array is subject to extreme operating conditions.</p> <p>3) AC and d.c. quantities may be distinguished by the addition of subscripts. In the case of multi-phase systems, parameters <math>V_L</math>, <math>I_L</math> and <math>P_L</math> shall be specified for each phase.</p> <p>4) A single current or power sensor can normally be used for the measurement of current or power for directions of both input and output. A positive sign in the sensor's output signal represents input to the energy storage device or utility grid and a negative sign represents output from the storage device or utility grid. Input and output from a single sensor must be accumulated separately in software.</p> <p>5) Tracker angles are optional for systems with tracking arrays. For single axis trackers <math>\phi_T</math> is used to describe the position of the array about its tracking axis. For example, for a horizontal single axis tracker this parameter would give the angle from horizontal, east is negative and west is positive.</p> <p>6) A direct measurement of the power output of the inverter portion of the power conditioner may be made if it improves accuracy.</p>		

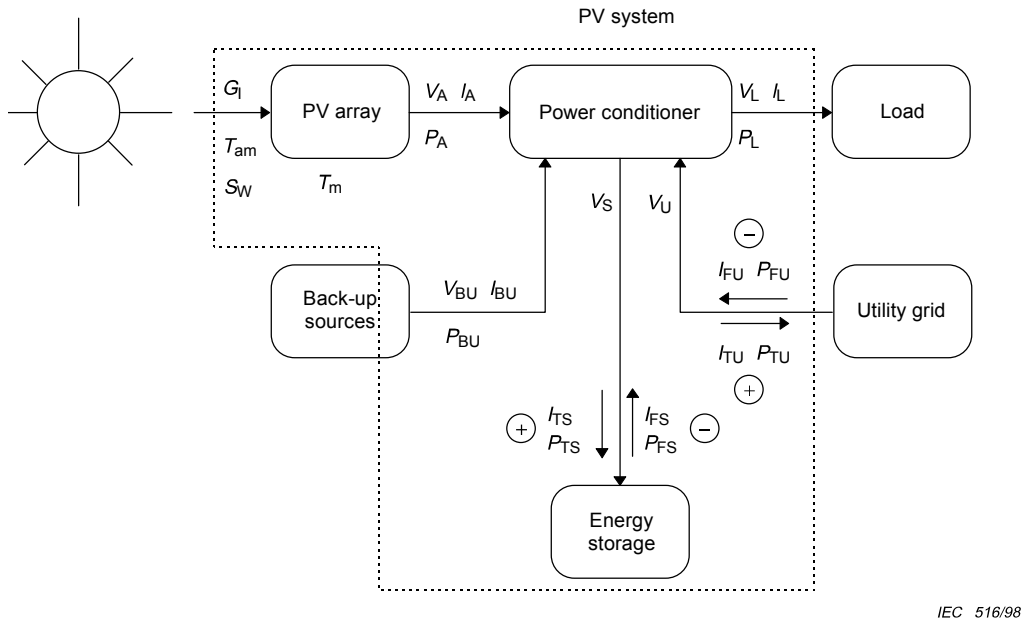

Figure 1 – Parameters to be measured in real time

## 4 Monitoring method

### 4.1 Measurement of irradiance

Irradiance data are recorded in the plane of the array for use in the performance analysis of the PV system. Horizontal data may also be recorded to permit comparisons with standard meteorological data from other locations.

In-plane irradiance shall be measured in the same plane as the photovoltaic array by means of calibrated reference devices or pyranometers. If used, reference cells or modules shall be calibrated and maintained in accordance with IEC 60904-2 or IEC 60904-6. The location of these sensors shall be representative of the irradiance conditions of the array. The accuracy of irradiance sensors, including signal conditioning, shall be better than 5 % of the reading.

### 4.2 Measurement of ambient air temperature

Ambient air temperature shall be measured at a location which is representative of the array conditions, by means of temperature sensors located in solar radiation shields. The accuracy of air temperature sensors, including signal conditioning, shall be better than 1 K.

### 4.3 Measurement of wind speed

Where applicable, wind speed shall be measured at a height and location which are representative of the array conditions. The accuracy of the wind speed sensors shall be better than  $0,5 \text{ m}\cdot\text{s}^{-1}$  for wind speeds  $\leq 5 \text{ m}\cdot\text{s}^{-1}$ , and better than 10 % of the reading for wind speeds greater than  $5 \text{ m}\cdot\text{s}^{-1}$ .



#### 4.4 Measurement of module temperature

PV module temperature shall be measured at locations which are representative of the array conditions by means of temperature sensors located on the back surface of one or more modules. The selection of module locations is specified under method A in IEC 61829. Care must be taken to ensure that the temperature of the cell in front of the sensor is not substantially altered due to the presence of the sensor. The accuracy of these sensors, including signal conditioning, shall be better than 1 K.

#### 4.5 Measurement of voltage and current

The voltage and current parameters may be either d.c. or a.c. The accuracy of voltage and current sensors, including signal conditioning, shall be better than 1 % of the reading. AC voltage and current may not need to be monitored in every situation.

#### 4.6 Measurement of electrical power

The electrical power parameters may be d.c. or a.c. or both. DC power can either be calculated in real time as the product of sampled voltage and current quantities or measured directly using a power sensor. If d.c. power is calculated, the calculations shall use sampled voltage and current quantities and not averaged voltage and current quantities<sup>1)</sup>. The d.c. input power and voltage on stand-alone inverters may have large amounts of a.c. ripple impressed. It may be necessary to use a d.c. wattmeter to accurately measure d.c. power. AC power shall be measured using a power sensor which properly accounts for the power factor and harmonic distortion. The accuracy of power sensors, including signal conditioning, shall be better than 2 % of the reading.

An integrating power sensor with high-speed response (for example, a kWh meter) may be used to avoid sampling errors.

#### 4.7 Data acquisition system

An automatic data acquisition system is required for monitoring. The total accuracy of the monitoring system shall be determined by a calibration method such as given in annex A. The monitoring system should be based on commercially available hardware and software which is properly documented with user's manuals. Technical support should be available.

#### 4.8 Sampling interval

The sampling interval for parameters which vary directly with irradiance shall be 1 min or less. For parameters which have larger time constants, an arbitrary interval may be specified between 1 min and 10 min. Special consideration for increasing the sampling frequency shall be given to any parameters which may change quickly as a function of system load. All parameters shall be continuously measured during the specified monitoring period.

---

<sup>1)</sup> The error between d.c. power as calculated from the averaged product of sampled voltage and sampled current and d.c. power as calculated from the product of averaged voltage and averaged current depends on the sample rate and the variation in current. Errors can be significant for large current variations.

NOTE – The rates of change for many of the parameters of interest can be relatively high. Irradiance, for example, can change at a rate exceeding  $200 \text{ W} \cdot \text{m}^{-2} \cdot \text{s}^{-1}$  under partly cloudy conditions. While the intent within this international standard is not to capture electrical transient-level detail, a sufficient sampling rate is necessary to characterize average performance over the averaging interval. Generally, the parameters in table 1 should be sampled every minute. Module and ambient temperature may be sampled at slower rates, but it is preferable as well as more convenient to sample all parameters at a common rate. All parameters should be continuously measured during the specified monitoring period.

#### 4.9 Data processing operation

The sampled data from each measured parameter shall be processed into time-weighted averages. Maximum or minimum quantities and transients of special interest may be determined where required. For integrating power sensors, the sampled data is summed and divided by the recording interval  $\tau_r$ .

#### 4.10 Recording interval, $\tau_r$ (expressed in hours)

The processed data values for each parameter shall be recorded hourly. More frequent recordings may be implemented where required, as long as one hour is an integer multiple of the recording interval  $\tau_r$ .

At each recording interval, the time and date at the end of the period in which measurements were taken shall be recorded. The time shall always refer to local standard time, not to daylight-saving time. Universal time may be useful to avoid winter/summer time changes.

#### 4.11 Monitoring period

The monitoring period shall be sufficient to provide operational data representative of load and ambient conditions. Therefore, the minimum period of continuous monitoring shall be chosen in accordance with the end use of the collected data.

### 5 Documentation

A monitoring log shall be kept on all unusual events, component changes, failures, faults or accidents. Other comments which would be useful in interpreting and evaluating the data shall also be noted, such as the weather, sensor recalibration, changes to the data acquisition system, load, or system operation, or problems with sensors or the data acquisition system. All system maintenance (such as changing modules, changing the array tilt angle or cleaning soiled array surfaces) shall be explicitly documented.

### 6 Data format

It is not mandatory that the data be stored nor exchanged in either of the following two illustrative formats. However, the first method based on separate header record and data records is in use in several countries, and may facilitate the exchange of data between organizations. For actual data transfer the line protocol terms, communication protocol and the check-sum terms must also be specified.

## 6.1 Separate header with multiple data records

This format gives a header record of the site, date, time and comments followed by one or more data records. A record is comparable to a printed line.

- a) Each record shall consist of one or more fields with each field separated by a field separation character (FS) which may be preferably a comma (ASCII 44), or optionally a tab (ASCII 9). The records should be separated by an "end-of-line" (EOL) marker consisting of a "carriage-return" character (ASCII 13), a "linefeed" character (ASCII 10), or a "carriage return" followed by a "linefeed".
- b) The header record shall be of the following form:

"Station" FS Date FS Time FS Comments

where

"Station" is the name of the site enclosed in double quotation marks (ASCII 34), of which only the first eight letters are mandatory;

Date is the day of the measurement in the format of yy-mm-dd (leading zeros should be included);

Time is the time of the recording in the format of hh:mm. Midnight should be referenced as 24 h in the previous day, not 0 h in the next day;

NOTE – Different formats of date and time may be necessary due to the unique software of the data acquisition system.

Comments may be used to describe additional system characteristics, or may be used to record unusual events, switching conditions or other messages at the discretion of the PV plant manager, using ASCII or Extended ASCII characters (or equivalent), corresponding to local character code standards.

- c) A data record shall consist of its record number as the first field, followed by one or more numerical data fields. The data fields are defined for the specific record as follows, using the symbols listed in table 1:

DATA RECORD 1: 1 FS  $G_I$  FS  $T_A$  FS  $T_m$  FS  $V_A$  FS  $I_A$  FS  $P_A$

DATA RECORD 2: 2 FS  $V_S$  FS  $I_{TS}$  FS  $I_{FS}$  FS  $P_{TS}$  FS  $P_{FS}$

DATA RECORD 3: 3 FS  $V_L$  FS  $I_L$  FS  $P_L$  FS  $V_{BU}$  FS  $I_{BU}$  FS  $P_{BU}$

DATA RECORD 4: 4 FS  $V_U$  FS  $I_{TU}$  FS  $I_{FU}$  FS  $P_{TU}$  FS  $P_{FU}$

Any number of additional data records may be optionally included in the recording interval. The content of these data records may be defined by the monitoring organization, with the exception of the first field which should indicate the record number.

- d) All numerical data shall be written in single-byte ASCII code. Data can be recorded, either in free-field or fixed-field format, as signed integers or decimal fractions with the period (ASCII 46) used as the radix (decimal point). If any numerical data field is not applicable to a PV installation or if a data value is not available for a record, an empty field should be indicated by an absence of characters. Thus, the FS character at the end of the empty data field would immediately follow the FS character from the preceding data field. However, all FS characters directly preceding the EOL marker should be suppressed. For example, in data record 2 if only  $I_{TS}$  and  $P_{TS}$  are available, then that record should be written as follows:

2 FS FS  $I_{TS}$  FS FS  $P_{TS}$  EOL

## 6.2 Single record format

Another format which can be used is the single record format in which all of the data for a given recording interval is listed on one line. This single record format aids visual inspection, particularly if used in conjunction with fixed field width since all of the data is given in a single vertical column for each parameter.

Data FS Time FS  $G_I$  FS  $T_A$  FS  $T_m$  FS  $V_A$  FS  $I_A$  FS  $P_A$  FS  $V_S$  FS  $I_{TS}$  FS  $I_{FS}$  etc.

Each field should be separated by a field separation character (FS) which may be preferably a comma (ASCII 44), or optionally a tab (ASCII 9).

## 7 Check of data quality

All recorded data should be checked for consistency and gaps to identify obvious anomalies before any detailed analysis is conducted.

A reasonable set of limits shall be defined for each recorded parameter, based on the known characteristics of the parameter, the PV plant, and the environment. The limits should define the maximum and minimum allowable values for the parameter, and the maximum change between successive data points. Data which fall outside these limits or are otherwise inconsistent with other data shall not be included in the subsequent analyses. If possible (such as with a computer-based data acquisition system), such checks shall be performed with the sampled data in real-time before the data processing operation is executed.

The results of these data quality checks should normally include the following information:

- a) a list of any data points falling outside the pre-set ranges;

NOTE – With automated systems collecting a large amount of data (megabytes), it is not practical to list the out-of-range data points. However, some monitoring of the quantity of the out-of-range data points should be made and reported. The out-of-range data points should not be used in the analyses.

- b) the duration of monitoring activity  $\tau_{MA}$  (expressed in hours), in the reporting period  $\tau$ , (commonly one month, but expressed in hours), for which monitoring data have been recorded and checked;
- c) the total number of hours of data passing through the quality check should also be stated if different than the duration of the actual quality check period selected;
- d) the availability of monitored data  $A_{MD}$  (expressed as a fraction of the reporting period), as given by:

$$A_{MD} = \tau_{MA} / \tau \quad (1)$$

## 8 Derived parameters

Various derived parameters related to the system's energy balance and performance may be calculated from the recorded monitoring data using sums, averages, maxima, minima, and ratios over reporting periods  $\tau$ , which are longer than the recording interval  $\tau_r$ , (such as hours, days, weeks, months or years, but expressed in units of hours). Derived parameters are shown in table 2.

To calculate any energy quantities from their corresponding measured power parameters over the reporting period  $\tau$ , the following equation is used:

$$E_{i,\tau} = \tau_r \times \sum_{\tau} P_i \quad (2)$$

where

$E_i$  is expressed in kWh;

$P_i$  is measured in kW.

The symbol  $\sum_{\tau}$  denotes the summation of each power parameter over the reporting period  $\tau$ .

For example, to calculate  $E_{TS,\tau}$  (as referenced in equation (4)) replace index "i" in equation (2) by "TS" so that it becomes  $E_{TS,\tau} = \tau_r \times \sum_{\tau} P_{TS}$ . Also replace index  $\tau$  by the actual reporting interval.

### 8.1 Global irradiation

Mean daily irradiation quantities  $H_{l,d}$  (in kWh·m<sup>-2</sup>·d<sup>-1</sup>) are calculated from the recorded irradiance by

$$H_{l,d} = 24 \times \tau_r \times (\sum_{\tau} G_l) / (\sum_{\tau} \tau_{MA} \ 1\ 000) \quad (3)$$

The symbol  $\sum_{\tau}$  denotes the summation over the reporting period  $\tau$ .

**Table 2 – Derived parameters**

Parameter	Symbol	Unit
Meteorology		
Daily global or direct irradiation, in the plane of the array	$H_{l,d}$	$\text{kWh}\cdot\text{m}^{-2}\cdot\text{d}^{-1}$
Electrical energy quantities		
Net energy from array	$E_{A,\tau}$	kWh
Net energy to load	$E_{L,\tau}$	kWh
Net energy to storage	$E_{TSN,\tau}$	kWh
Net energy from storage	$E_{FSN,\tau}$	kWh
Net energy from back-up	$E_{BU,\tau}$	kWh
Net energy to utility grid	$E_{TUN,\tau}$	kWh
Net energy from utility grid	$E_{FUN,\tau}$	kWh
Total system input energy	$E_{in,\tau}$	kWh
Total system output energy	$E_{use,\tau}$	kWh
Fraction of total system input energy contributed by PV array	$F_{A,\tau}$	Dimensionless
Load efficiency	$\eta_{LOAD}$	Dimensionless
BOS component performance		
BOS efficiency	$\eta_{BOS}$	Dimensionless
System performance indices		
Array yield <sup>1)</sup>	$Y_A$	$\text{h}\cdot\text{d}^{-1}$
Final PV system yield <sup>1)</sup>	$Y_f$	$\text{h}\cdot\text{d}^{-1}$
Reference yield <sup>1)</sup>	$Y_r$	$\text{h}\cdot\text{d}^{-1}$
Array capture losses <sup>1)</sup>	$L_c$	$\text{h}\cdot\text{d}^{-1}$
BOS losses <sup>1)</sup>	$L_{BOS}$	$\text{h}\cdot\text{d}^{-1}$
Performance ratio	$R_p$	Dimensionless
Mean array efficiency	$\eta_{Amean,\tau}$	Dimensionless
Overall PV plant efficiency	$\eta_{tot,\tau}$	Dimensionless
1) The units $\text{h}\cdot\text{d}^{-1}$ can be more descriptively given by $(\text{kWh}\cdot\text{d}^{-1})_{ACTUAL}/(\text{kW})_{RATED}$		

## 8.2 Electrical energy quantities

Electrical energy quantities can be calculated for the whole system and its components including energy delivered to or from a storage device or utility grid connection, or delivered from an auxiliary generator. The key parameters of interest are those which indicate the contribution of the PV array to the overall operation of the system.

- a) The net energy delivered to the storage device in the reporting period  $\tau$ :

$$E_{TSN,\tau} = E_{TS,\tau} - E_{FS,\tau} \quad (4)$$

where  $E_{TSN,\tau}$  has a minimum value of 0.

- b) The net energy delivered from the storage device in the reporting period  $\tau$ :

$$E_{FSN,\tau} = E_{FS,\tau} - E_{TS,\tau} \quad (5)$$

where  $E_{FSN,\tau}$  has a minimum value of 0.

NOTE – Either  $E_{TSN,\tau}$  or  $E_{FSN,\tau}$  will always be 0. By using net energy quantities rather than gross energy, the storage device is considered as either a net load or a net energy source during the reporting period.

- c) The net energy delivered to the utility grid in the reporting period  $\tau$ :

$$E_{TUN,\tau} = E_{TU,\tau} - E_{FU,\tau} \quad (6)$$

where  $E_{TUN,\tau}$  has a minimum value of 0.

- d) The net energy delivered from the utility grid in the reporting period  $\tau$ :

$$E_{FUN,\tau} = E_{FU,\tau} - E_{TU,\tau} \quad (7)$$

where  $E_{FUN,\tau}$  has a minimum value of 0.

NOTE – Either  $E_{TUN,\tau}$  or  $E_{FUN,\tau}$  will always be 0. By using net energy quantities rather than gross energy, the utility grid is considered as either a net load or a net energy source during the reporting period.

- e) The total system input energy:

$$E_{in,\tau} = E_{A,\tau} + E_{BU,\tau} + E_{FUN,\tau} + E_{FSN,\tau} \quad (8)$$

- f) The total system output energy:

$$E_{use,\tau} = E_{L,\tau} + E_{TUN,\tau} + E_{TSN,\tau} \quad (9)$$

- g) The fraction of the energy from all sources which was contributed by the PV array:

$$F_{A,\tau} = E_{A,\tau} / E_{in,\tau} \quad (10)$$

- h) The efficiency with which the energy from all sources is transmitted to the loads:

$$\eta_{LOAD} = E_{use,\tau} / E_{in,\tau} \quad (11)$$

## 8.3 BOS component performance

The BOS efficiency only includes energy conversion efficiency; such things as array tracking error and PCU maximum power point tracking error are excluded.

For each component in the system, the energy balance over the reporting period can be determined by summing the energy quantities into and out of the component. The component energy efficiency is the quotient of energy output over energy input.

The overall efficiency of the BOS components is given by

$$\eta_{\text{BOS}} = (E_{L,\tau} + E_{\text{TSN},\tau} - E_{\text{FSN},\tau} + E_{\text{TUN},\tau} - E_{\text{FUN},\tau}) / (E_{A,\tau} + E_{\text{BU},\tau}) \quad (12)$$

For PV hybrid systems and utility grid-connected systems where  $E_{L,\tau}$  is less than  $E_{A,\tau} \times \eta_{\text{BOS}}$ , and for all PV stand-alone systems,  $\eta_{\text{LOAD}}$  equals  $\eta_{\text{BOS}}$ . For utility grid-connected systems where  $E_{L,\tau}$  is greater than  $E_{A,\tau} \times \eta_{\text{BOS}}$ ,  $\eta_{\text{LOAD}}$  will be greater than  $\eta_{\text{BOS}}$  because the utility appears as a loss-less energy source to the PV system.

Both the efficiency of the energy storage device and the change in the amount of energy stored in the device over the reporting period will affect  $E_{\text{FS},\tau}$  and  $E_{\text{TS},\tau}$ .

- a) For long reporting periods in which  $E_{\text{TS},\tau}$  and  $E_{\text{FS},\tau}$  are much greater than the device's energy storage capacity (by more than a factor of 10), the net energy added to or removed from the device can be assumed to have a negligible effect on the system performance calculations. Any difference between  $E_{\text{TS},\tau}$  and  $E_{\text{FS},\tau}$  is then primarily due to the efficiency of the device. As a result,  $E_{\text{TS},\tau}$  and  $E_{\text{FS},\tau}$  should be deleted from all equations to include the device's efficiency with the  $\eta_{\text{LOAD}}$  and  $\eta_{\text{BOS}}$  values. This condition is typical when reporting periods are of several months. The maximum possible effect on the accumulated  $E_{\text{TS},\tau}$  or  $E_{\text{FS},\tau}$  due to the actual change in the energy stored in the device can be calculated from the quotient of the device's storage capacity over  $E_{\text{TS},\tau}$  or  $E_{\text{FS},\tau}$ .
- b) For short reporting periods in which the energy storage capacity of the device is much greater than  $E_{\text{TS},\tau}$  and  $E_{\text{FS},\tau}$  (by more than a factor of 10), the efficiency of the device can be assumed to have a negligible effect on the system performance calculations. Any difference between  $E_{\text{TS},\tau}$  and  $E_{\text{FS},\tau}$  is then primarily due to the change in the amount of energy stored in the device. As a result,  $E_{\text{TS},\tau}$  and  $E_{\text{FS},\tau}$  become important terms in the system performance calculations. This condition is typical when reporting periods are of only a few days. The typical effect on  $E_{\text{TS},\tau}$  and  $E_{\text{FS},\tau}$  due to the efficiency of the device can be calculated from known measurements of the device's efficiency.

## 8.4 System performance indices

PV systems of different configurations and at different locations can be readily compared by evaluating their normalised system performance indices such as yields, losses and efficiencies. Yields are energy quantities normalised to rated array power. System efficiencies are normalised to array area. Losses are the differences between yields.

NOTE – The performance indices of grid-connected, stand-alone and hybrid systems can differ significantly due to load matching and other unique operating characteristics.

### 8.4.1 Daily mean yields

Daily mean yields are the quotient of energy quantities over the installed array's rated output power  $P_0$  (kW). The yields have units of  $\text{kWh}\cdot\text{d}^{-1}\cdot\text{kW}^{-1}$  (or  $\text{h}\cdot\text{d}^{-1}$ ) and indicate the amount of time during which the array would be required to operate at  $P_0$  to provide a particular monitored energy quantity. Yields indicate actual array operation relative to its rated capacity.



- a) The array yield  $Y_A$  is the daily array energy output per kW of installed PV array:

$$Y_A = E_{A,d} / P_0 = \tau_r \times (\Sigma_{\text{day}} P_A) / P_0 \quad (13)$$

The symbol  $\Sigma_{\text{day}}$  denotes the summation for the day. This yield represents the number of hours per day that the array would need to operate at its rated output power  $P_0$  to contribute the same daily array energy to the system as was monitored (which equals  $\tau_r \times (\Sigma_{\text{day}} P_A)$ ).

- b) The final PV system yield  $Y_f$  is the portion of the daily net energy output of the entire PV plant which was supplied by the array per kW of installed PV array:

$$Y_f = Y_A \times \eta_{\text{LOAD}} \quad (14)$$

This yield represents the number of hours per day that the array would need to operate at its rated output power  $P_0$  to equal its monitored contribution to the net daily load.

- c) The reference yield  $Y_r$  can be calculated by dividing the total daily in-plane irradiation by the module's reference in-plane irradiance  $G_{I,\text{ref}}$  ( $\text{kW}\cdot\text{m}^{-2}$ ):

$$Y_r = \tau_r \times (\Sigma_{\text{day}} G_I) / G_{I,\text{ref}} \quad (15)$$

This yield represents the number of hours per day during which the solar radiation would need to be at reference irradiance levels in order to contribute the same incident energy as was monitored. If  $G_{I,\text{ref}} = 1 \text{ kW}\cdot\text{m}^{-2}$ , then the in-plane irradiation in units of  $\text{kWh}\cdot\text{m}^{-2}\cdot\text{d}^{-1}$  is numerically equal to a corresponding nominal array energy output in units of  $\text{kWh}\cdot\text{d}^{-1}\cdot\text{kW}^{-1}$ . Thus  $Y_r$  would be, in effect, the number of peak sun-hours per day ( $\text{h}\cdot\text{d}^{-1}$ ).

#### 8.4.2 Normalized losses

Normalized losses are calculated by subtracting yields. Losses also have units of  $\text{kWh}\cdot\text{d}^{-1}\cdot\text{kW}^{-1}$  (or  $\text{h}\cdot\text{d}^{-1}$ ) and indicate the amount of time during which the array would be required to operate at its rated power  $P_0$  to provide for the losses.

- a) The "array capture" losses  $L_c$  represents the losses due to array operation:

$$L_c = Y_r - Y_A \quad (16)$$

- b) The BOS losses  $L_{\text{BOS}}$  represents the losses in the BOS components:

$$L_{\text{BOS}} = Y_A \times (1 - \eta_{\text{BOS}}) \quad (17)$$

- c) The performance ratio  $R_P$  indicates the overall effect of losses on the array's rated output due to array temperature, incomplete utilisation of the irradiation, and system component inefficiencies or failures:

$$R_P = Y_f / Y_r \quad (18)$$

#### 8.4.3 System efficiencies

- a) The mean array efficiency over the reporting period  $\tau$  is defined by:

$$\eta_{A\text{mean}, \tau} = E_{A, \tau} / (A_a \times \tau_r \times \Sigma_{\tau} G_I) \quad (19)$$

where  $A_a$  is the overall array area.

This efficiency represents the mean energy conversion efficiency of the PV array, which is useful for comparison with the array efficiency  $\eta_{A0}$  at its rated power,  $P_0$ . The difference in efficiency values represents diode, wiring, and mismatch losses as well as energy wasted during plant operation.

b) The overall PV plant efficiency over the reporting period  $\tau$  is defined by:

$$\eta_{\text{tot},\tau} = \eta_{\text{Amean},\tau} \times \eta_{\text{LOAD}} \quad (20)$$

#### 8.4.4 Monthly or annual yields, losses and efficiencies

The monthly or annual mean yields can be determined by using the appropriate array energy in equation (13) ( $E_{A,m}$  for monthly or  $E_{A,y}$  for annual), and the appropriate summation period ( $\Sigma_m$  for monthly or  $\Sigma_y$  for annual summations). The array yield would have units of  $\text{h}\cdot\text{m}^{-1}$  for monthly yield or  $\text{h}\cdot\text{y}^{-1}$  for annual yield.

Similar monthly or annual yields  $Y_f$ , reference yields  $Y_r$ , losses and efficiencies can be determined by using the proper array yield and summation periods in equation (14) through (20). Other monthly or annual performance factors may be included to satisfy the user requirements.

## **Annex A** (informative)

### **A suggested method of checking the data acquisition system**

A data acquisition system excluding sensors can be checked by applying the simulated input signals specified below, or by other means agreed upon between the manufacturer and the customer. A check should be made every two years. Sensors should be calibrated individually in an appropriate manner.

The channels of the data acquisition equipment can be checked separately or at the same time.

#### **A.1 Types of input signals to be checked**

- irradiance;
- ambient temperature;
- voltage, current and power for each component of the PV plant.

#### **A.2 Check of linear response**

This check is to be performed on analogue input channels on which a linear scaling operation is applied. A constant d.c. signal shall be applied to the input terminals. The difference between the result measured by the data acquisition system and the products of the input signal value and scaling factor shall be less than  $\pm 1$  % of the full scale of the data acquisition system. This procedure should be performed at input signals of 0 %, 20 %, 40 %, 60 %, 80 %, and 100 % of full scale. If the inputs are specified for bipolar signals, negative signals shall also be applied in the same way.

If errors greater than 1 % of full scale are detected, then the scale factor should be corrected by software or hardware and re-verified.

#### **A.3 Check of stability**

This check is to be performed on all analogue input channels. A constant d.c. signal of 100 % of full scale shall be applied to the input terminals for 6 h. The fluctuation of the measured value of this signal shall be kept within  $\pm 1$  % of full scale. Should the fluctuation of the input signal exceed  $\pm 0,2$  %, the results shall be compensated by using a voltmeter with an accuracy better than  $\pm 0,2$  %.

#### **A.4 Check of integration**

This check is to be performed on input channels from which measurements are to be processed using an averaging or integrating operation. An input signal of a rectangular wave having an amplitude  $Z_m$  shall be applied to the channel and its measured values integrated over time period  $\tau_d$  (recommended to be at least 6 h). The amplitude  $Z_m$  for each channel is recommended to be the maximum input level expected from the sensor. The results obtained shall be equal to  $Z_m \times \tau_d \pm 1$  %. The amplitude and time period shall be monitored by measuring instruments with a  $\pm 0,5$  % precision.

### **A.5 Check of zero value integrals**

This check is to be performed on input channels from which measurements are to be processed using an averaging or integrating operation. The channel shall be short-circuited, and its measured values integrated over time period  $\tau_d$  of at least 6 h. The result shall be less than  $\pm 1\%$  of  $Z_m \times \tau_d$  where  $Z_m$  is defined in A.4.

### **A.6 Check of integrating interval**

Under consideration.

---



Standards Survey

The IEC would like to offer you the best quality standards possible. To make sure that we continue to meet your needs, your feedback is essential. Would you please take a minute to answer the questions overleaf and fax them to us at +41 22 919 03 00 or mail them to the address below. Thank you!

Customer Service Centre (CSC)

**International Electrotechnical Commission**

3, rue de Varembé

1211 Genève 20

Switzerland

or

Fax to: **IEC/CSC** at +41 22 919 03 00

Thank you for your contribution to the standards-making process.

**A Prioritaire**

Nicht frankieren  
Ne pas affranchir



Non affrancare  
No stamp required

**RÉPONSE PAYÉE**

**SUISSE**

Customer Service Centre (CSC)

**International Electrotechnical Commission**

3, rue de Varembé

1211 GENEVA 20

Switzerland

LICENSED TO MECON Limited. - RANCHI/BANGALORE  
FOR INTERNAL USE AT THIS LOCATION ONLY, SUPPLIED BY BOOK SUPPLY BUREAU.





Enquête sur les normes

La CEI ambitionne de vous offrir les meilleures normes possibles. Pour nous assurer que nous continuons à répondre à votre attente, nous avons besoin de quelques renseignements de votre part. Nous vous demandons simplement de consacrer un instant pour répondre au questionnaire ci-après et de nous le retourner par fax au +41 22 919 03 00 ou par courrier à l'adresse ci-dessous. Merci !

Centre du Service Clientèle (CSC)

**Commission Electrotechnique Internationale**

3, rue de Varembé  
1211 Genève 20  
Suisse

ou

Télécopie: **CEI/CSC** +41 22 919 03 00

Nous vous remercions de la contribution que vous voudrez bien apporter ainsi à la Normalisation Internationale.

**A Prioritaire**

Nicht frankieren  
Ne pas affranchir



Non affrancare  
No stamp required

**RÉPONSE PAYÉE**

**SUISSE**

Centre du Service Clientèle (CSC)  
**Commission Electrotechnique Internationale**  
3, rue de Varembé  
1211 GENÈVE 20  
Suisse

LICENSED TO MECON Limited. - RANCHI/BANGALORE  
FOR INTERNAL USE AT THIS LOCATION ONLY, SUPPLIED BY BOOK SUPPLY BUREAU.



- LICENSED TO MECON Limited, - RANCHI/BANGALORE  
FOR INTERNAL USE AT THIS LOCATION ONLY, SUPPLIED BY BOOK SUPPLY BUREAU.